

酒匂川流域下水道台帳

施設平面縦断図(図面番号 1)

幹線名 連絡幹線

1 : 500

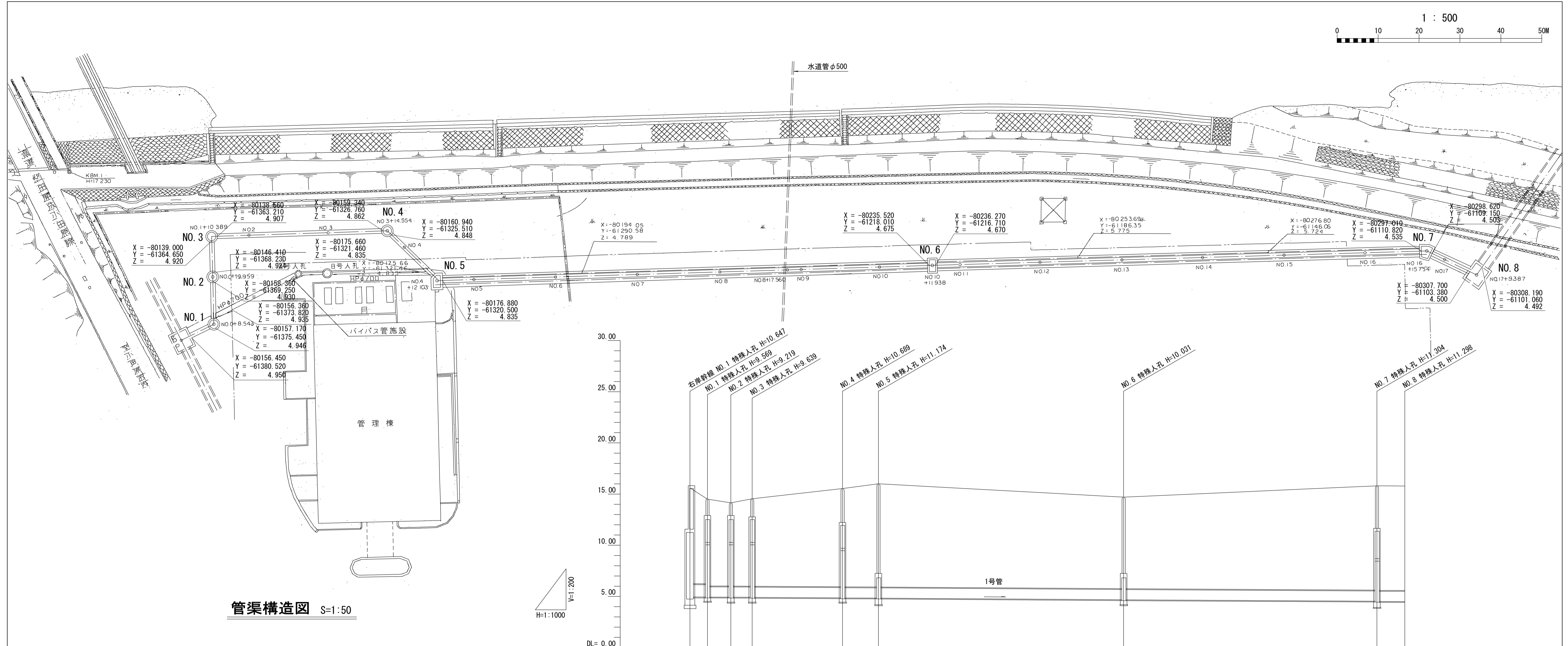

管渠構造図 S=1:50

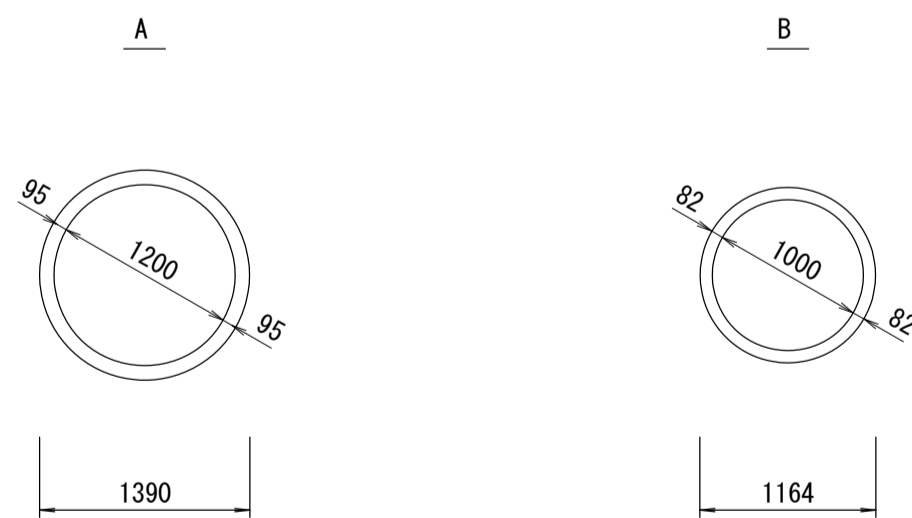

施工区	第101工区(その1)										第101工区(その2)															
	A					B																				
占用区間																										
管渠築造																										
土被り	8.497	8.263	8.263	8.131	8.137		9.593	9.607		10.087	10.092		8.544	8.549		10.190	10.222									
地盤高	15.597	14.504	14.143	14.143	14.546	14.762	15.210	15.537	15.683	16.009	15.923	15.705	15.486	15.268	15.050	14.831	14.701	14.773	14.952	15.130	15.309	15.488	15.666	15.807	15.802	15.790
管底高	4.950	4.946	4.935	4.930	4.924	4.907	4.862	4.848	4.840	4.835		4.840	4.835		4.675	4.670		4.535	4.503		4.535	4.503		4.535	4.503	4.492
追加距離	0.000	8.543	19.959	30.389	40.000		60.000	74.554	80.000	92.103	100.000	120.000	140.000	160.000	180.000	200.000	211.938	220.000	240.000	260.000	280.000	300.000	320.000	335.754	340.000	349.387
区間距離	0.000	8.543	11.416	10.430	9.611		20.000	14.554	5.446	12.103	7.897	20.000	20.000	20.000	20.000	11.938	8.062	20.000	20.000	20.000	20.000	20.000	20.000	15.754	4.246	9.387
測点	No.0	No.0	No.0	No.1	No.2		No.3	No.3	No.4	No.4	No.5	No.6	No.7	No.8	No.9	No.10	No.10	No.11	No.12	No.13	No.14	No.15	No.16	No.16	No.17	No.17
曲線	$68^{\circ} 20' 34''$ $176^{\circ} 08' 22''$ $273^{\circ} 52' 44''$ $226^{\circ} 46' 21''$ $138^{\circ} 23' 32''$ $179^{\circ} 59' 38''$ $208^{\circ} 13' 46''$ $98^{\circ} 12' 08''$																									

酒匂川流域下水道台帳

施設平面縦断図(図面番号 2)

幹線名 連絡幹線

1 : 500

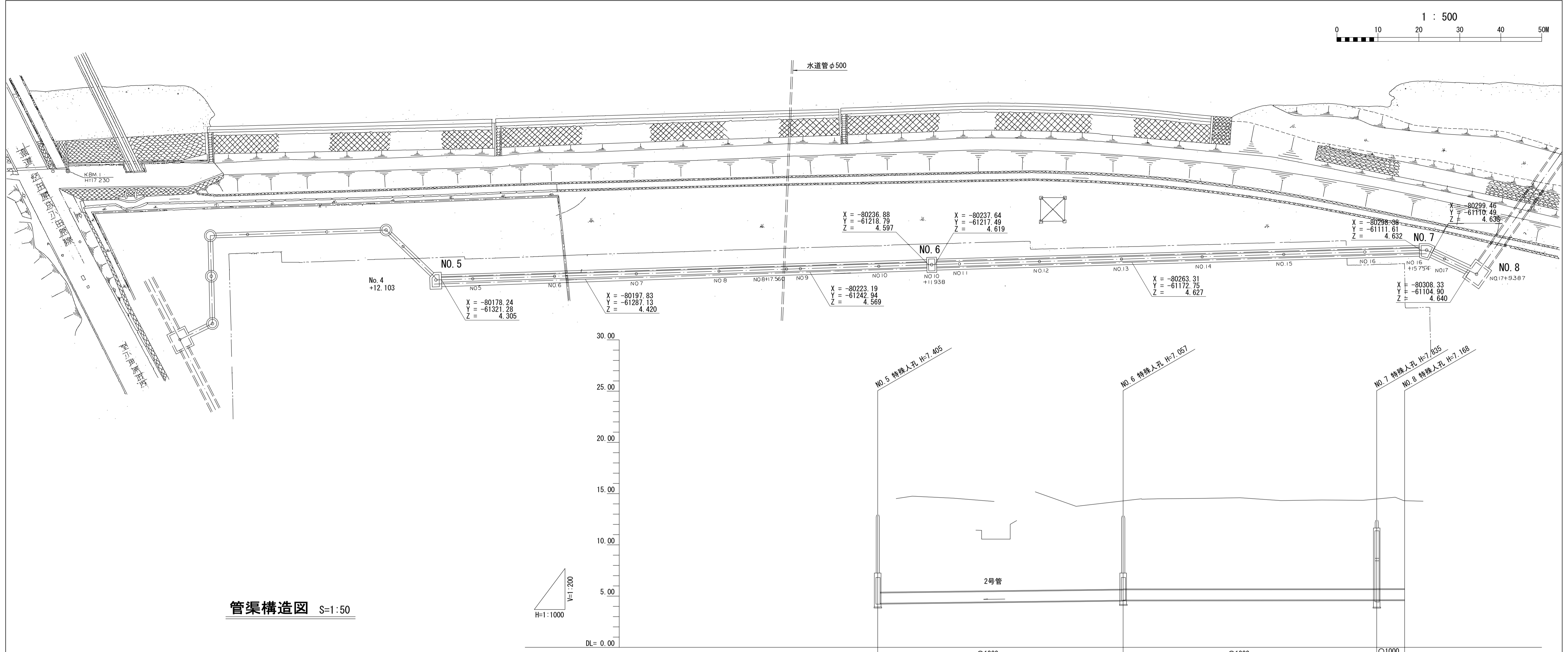
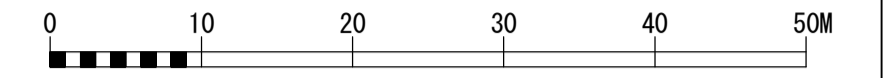

管渠構造図 S=1:50

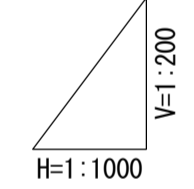

DL=0.00

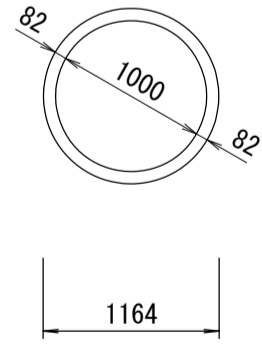

施工区	第101工区(その1)										第101工区(その2)								
占用区間																			
管渠築造																			
土被り	6.323										6.322 5.953							131 5.976	
地盤高	11.710	11.962	11.752	11.434	12.371	10.964	11.701	11.654	11.695	11.727	11.795	11.517	11.576	11.546	11.851	11.699	11.508	11.460	
管底高	4.305						4.597	4.619							4.632	4.638		4.640	
追加距離	36.200	44.097	64.097	84.097	104.097	124.097	144.097	156.035	164.097	184.097	204.097	224.097	244.097	264.097	279.851	284.097	293.404		
区間距離	3.360	7.897	20.000	20.000	20.000	20.000	20.000	11.938	8.062	20.000	20.000	20.000	20.000	20.000	15.754	4.246	9.387		
測点	No.4 +12.103	No.5	No.6	No.7	No.8	No.9	No.10	No.10 +11.308	No.11	No.12	No.13	No.14	No.15	No.16	No.16 +15.754	No.17	No.17 +9.387		
曲線	<div style="display: flex; justify-content: space-around;"> 179° 59' 38" 208° 13' 46" </div>																		

酒匂川流域下水道台帳

施設平面縦断図(図面番号 3)

幹線名 連絡幹線

1 : 500

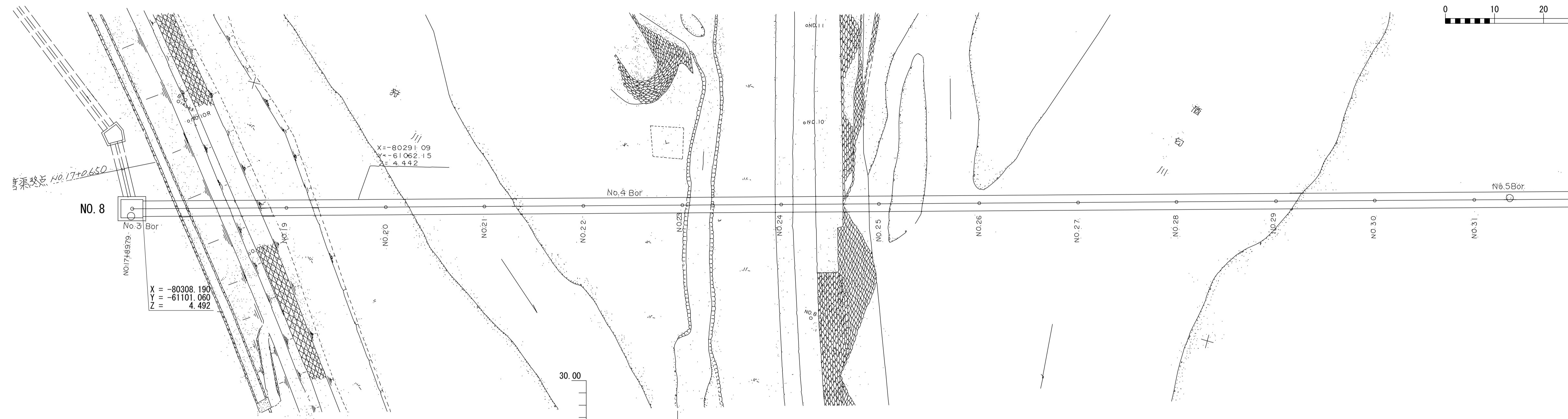

X = -90308.190
Y = -61101.060
Z = 4.492

X = -60291.09
Y = -61062.15
Z = 4.442

管渠構造図 S=1:50

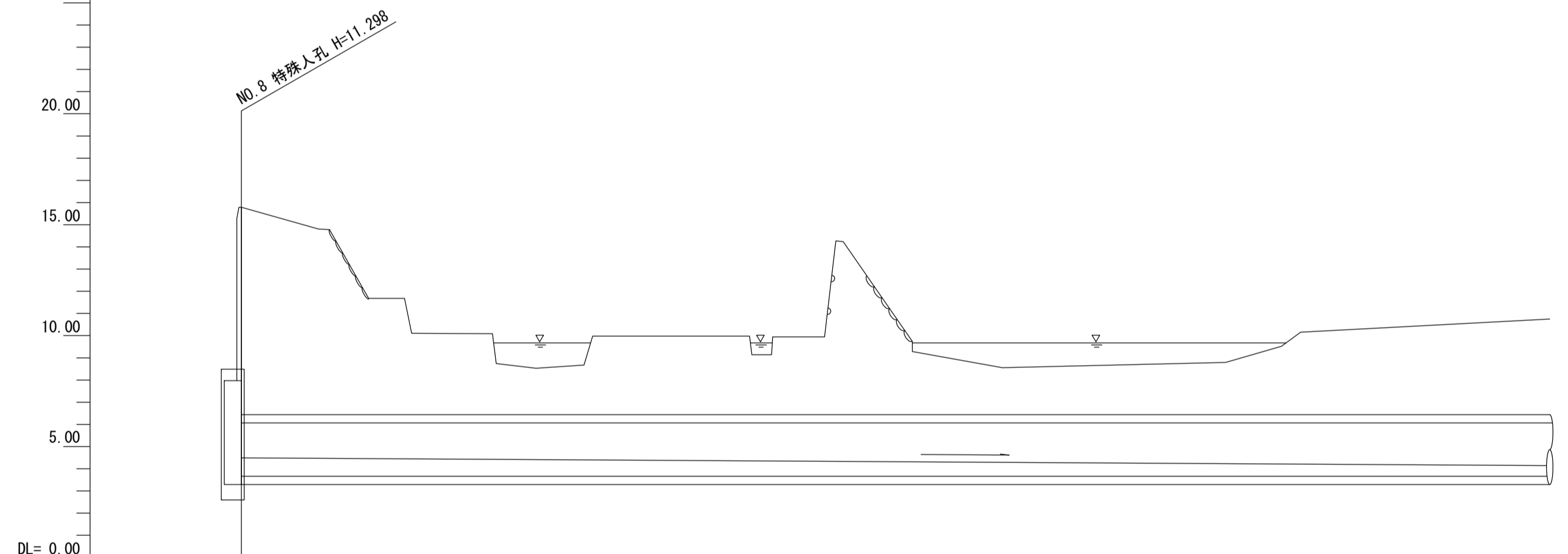
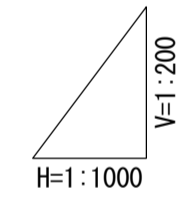

○1200
i=1.17‰ L=447.454m

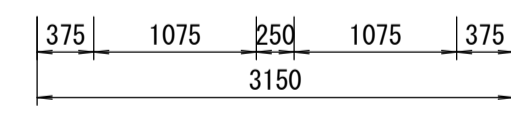
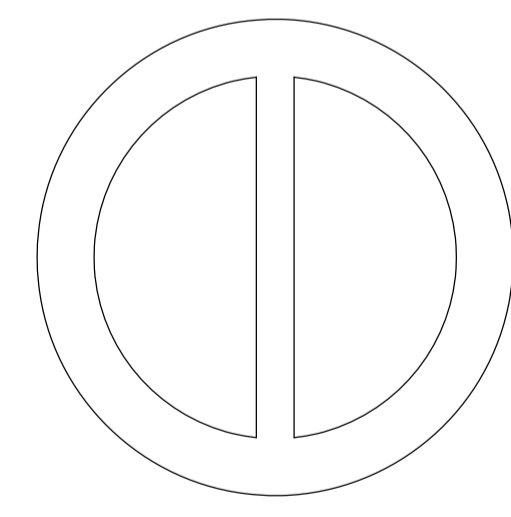

施工区	第102工区															
占用区間	小田原土木(河川)															
管渠築造																
土被り	10.208 10.216															
地盤高	15.790	13.350	11.665	10.190	8.600	10.050	10.045	10.025	9.300	8.680	8.720	8.850	9.550	10.480	10.650	10.920
管底高	4.500 4.492															
追加距離	348.387	360.000	380.000	400.000	420.000	440.000	460.000	480.000	500.000	520.000	540.000	560.000	580.000	600.000	620.000	640.000
区間距離	9.387	10.613	20.000	20.000	20.000	20.000	20.000	20.000	20.000	20.000	20.000	20.000	20.000	20.000	20.000	20.000
測点	No.17 +9.387	No.18	No.19	No.20	No.21	No.22	No.23	No.24	No.25	No.26	No.27	No.28	No.29	No.30	No.31	No.32
曲線																

酒匂川流域下水道台帳

施設平面縦断図(図面番号 4)

幹線名 連絡幹線

1 : 500

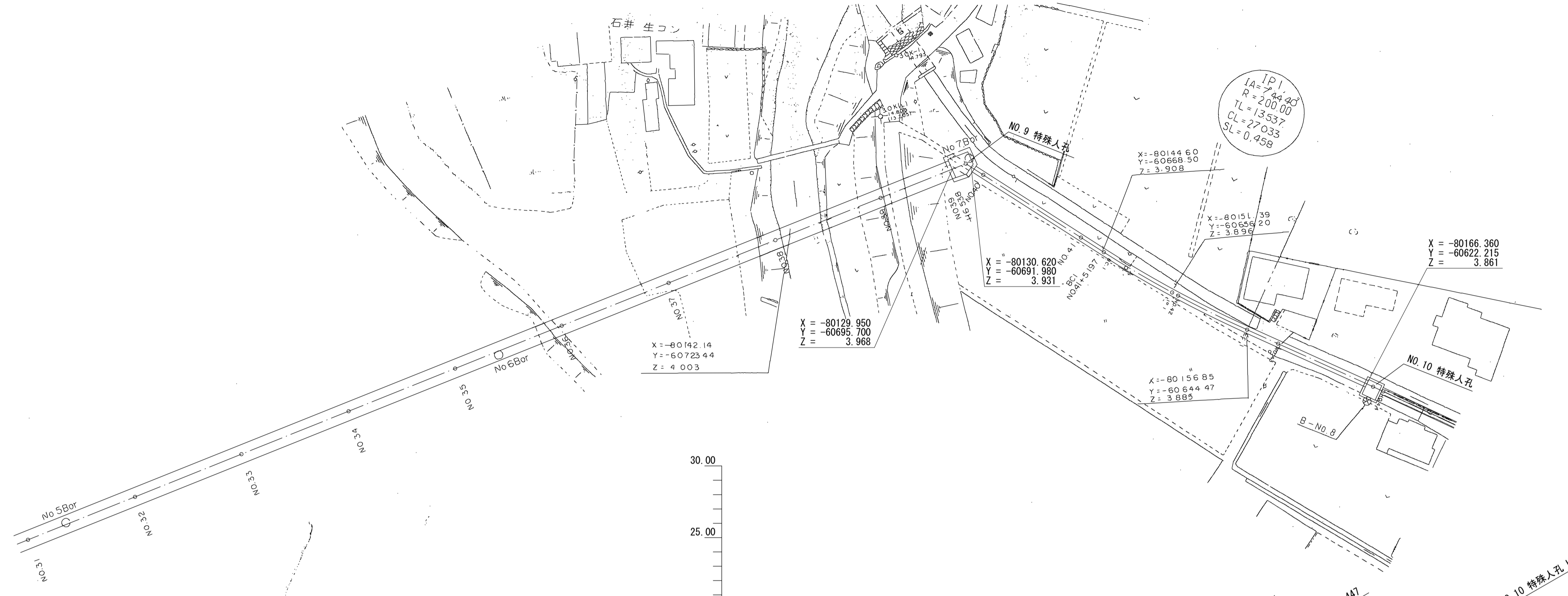

管渠構造図 S=1:50

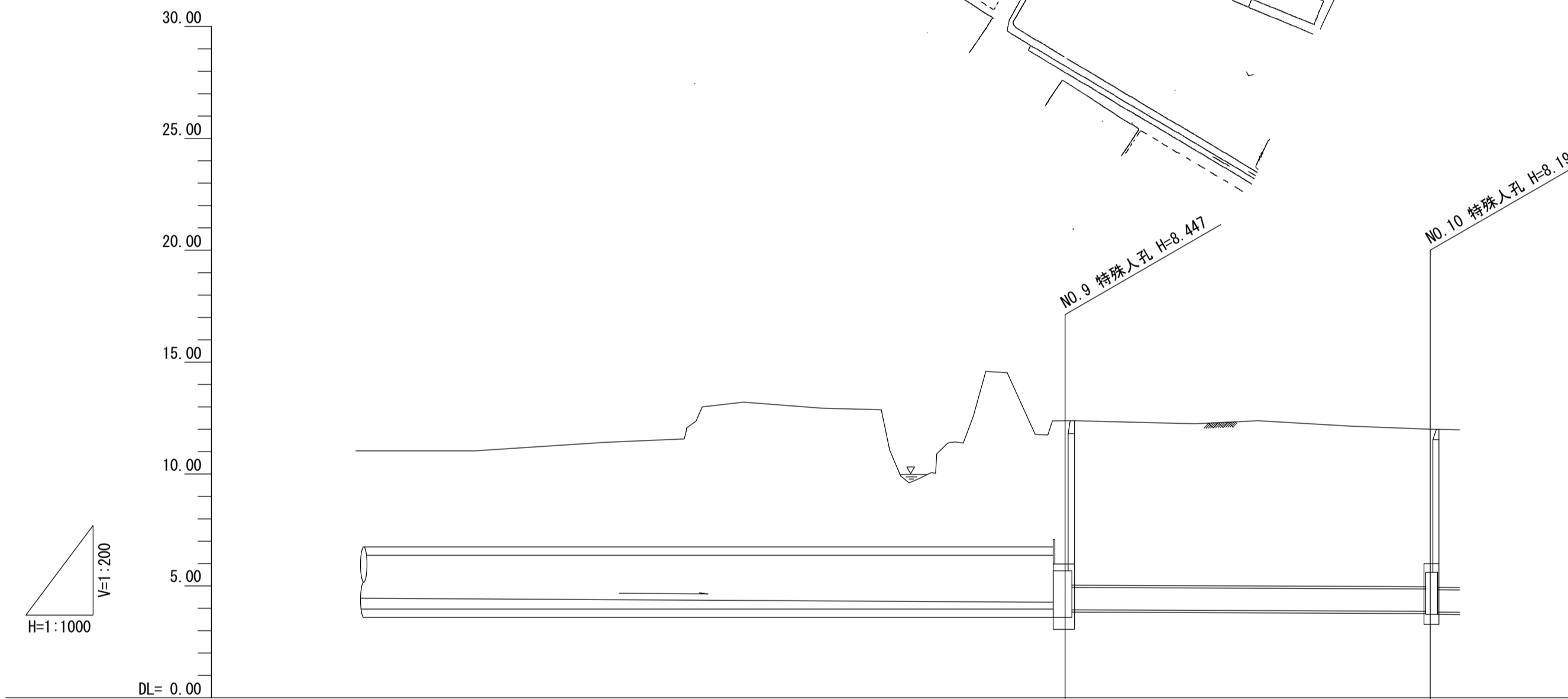
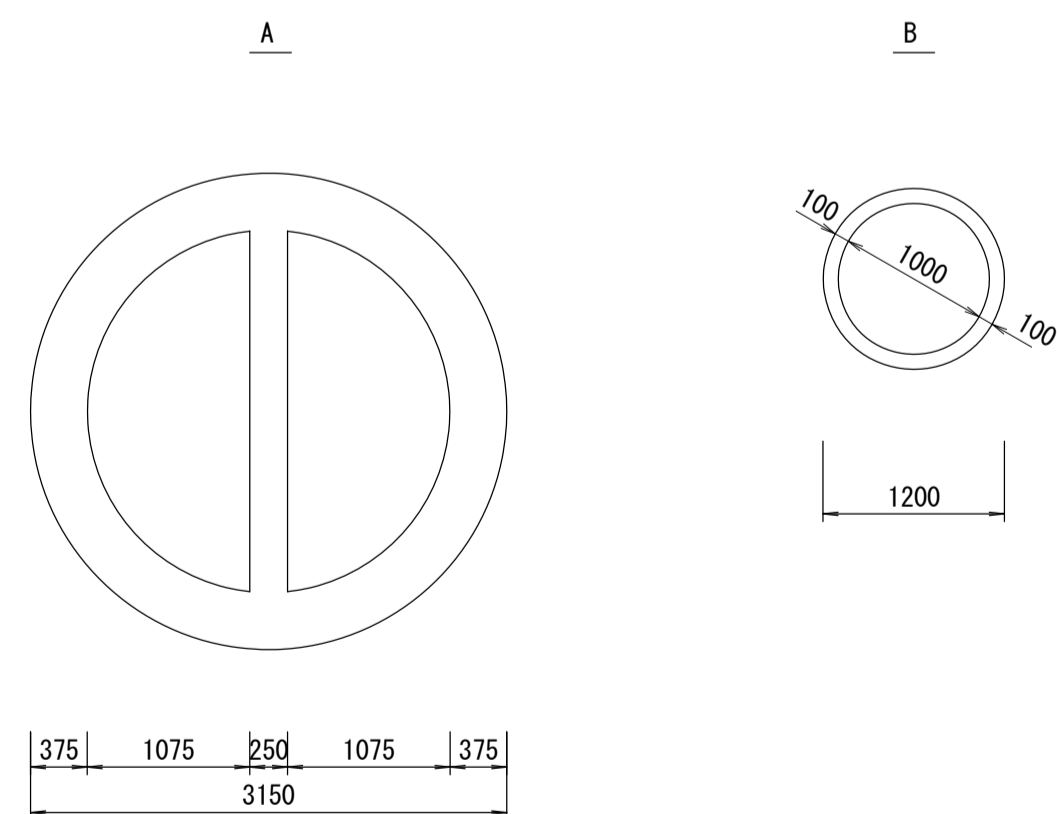

施工区	第102工区										第103工区(その1)											
占用区間	小田原土木(河川)										小田原市(認定外道路)											
管渠築造	A										B											
土被り											7.095	7.365			7.064	7.116						
地盤高											12.278		12.212	12.246	12.335	12.387	12.243	12.155	12.027	12.027		
管底高											3.969	3.931							3.861	3.823		
追加距離		640.000	660.000	680.000	700.000	720.000	740.000	760.000	780.000		796.844	800.000	820.000	825.902	839.419	840.000	852.935	860.000	878.499			
区間距離		20.000	20.000	20.000	20.000	20.000	20.000	20.000	20.000		16.841	3.159	20.000	5.902	13.517	0.581	12.935	7.065	18.499			
測点		No. 32	No. 33	No. 34	No. 35	No. 36	No. 37	No. 38	No. 39		+16.841	No. 40	No. 41	BC. 1	SP. 1	No. 42	EC. 1	No. 43	No. 43	+18.499		
曲線											IP. 1 IA=7.44-40 R=200.000 TL=13.537 CL=27.033 SL=0.458											

酒匂川流域下水道台帳

施設平面縦断面図(図面番号 5)

幹線名 連絡幹線

1 : 500

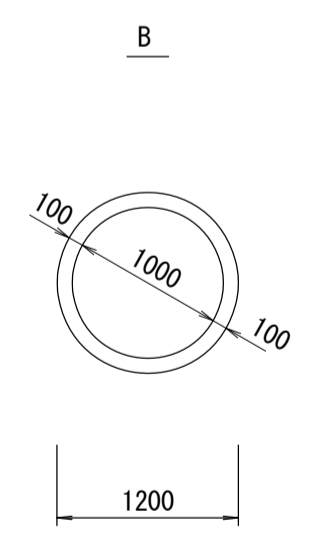
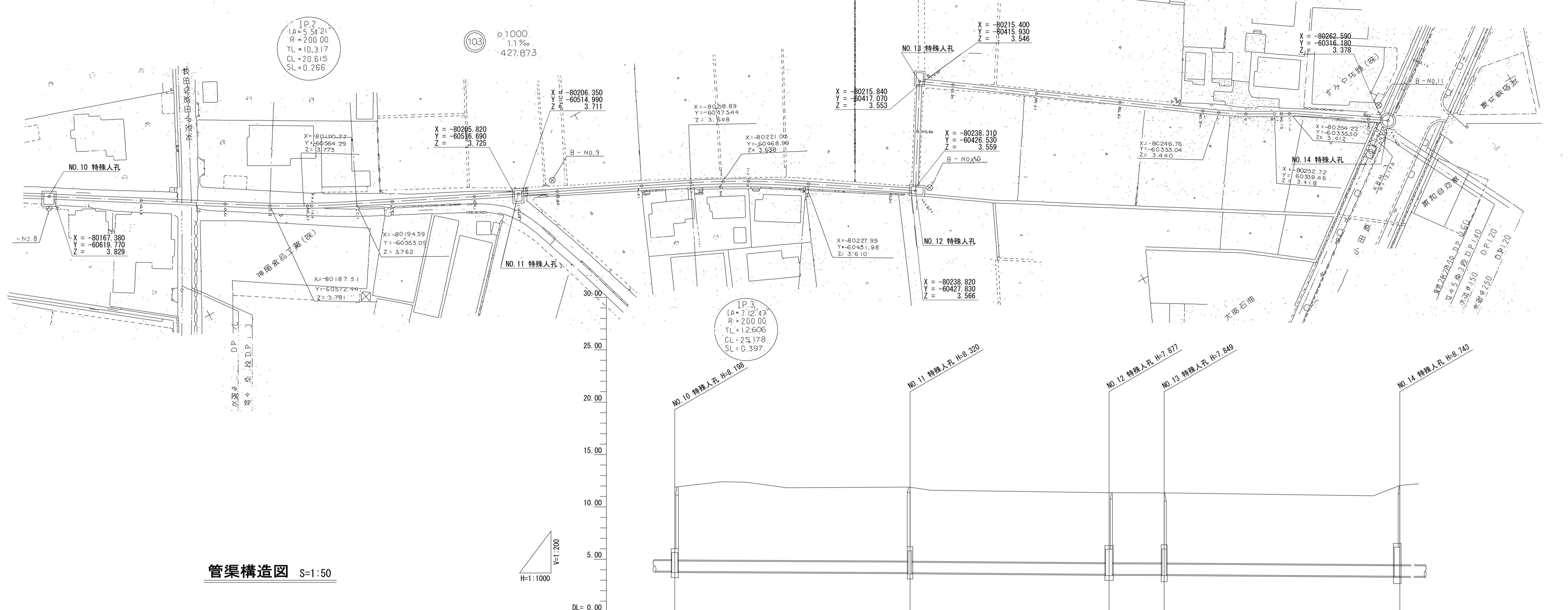
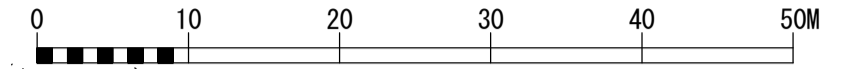

施工区	第103工区(その2)										第103工区(その3)																															
占有区間	小田原市(認定外道路)					小田原市(市道)					小田原市(認定外道路)					小田原市(市道)																										
管渠築造	小田原松田線																																									
土被り	7.046	7.096								7.206	7.176						6.765	6.776					6.742	6.746				7.606	7.643													
地盤高	12.007	12.026	12.458	11.926	11.944	11.944	11.922	11.932	11.929	12.031	11.986	11.716	11.646	11.611	11.592	11.577	11.534	11.531	11.452	11.431	11.436	11.406	11.395	11.392	11.377	11.316	11.252	11.183	11.177	11.154	11.148	11.150	11.161	11.814	12.084	12.116						
管底高	3.861	3.829							3.725	3.711							3.566	3.559	3.553	3.546								3.378	3.373													
追加距離	878.499	880.000	900.000	920.000	940.000	941.532	951.839	960.000	980.000	990.822	1000.000	1020.000	1033.203	1040.000	1045.792	1058.382	1060.000	1080.000	1085.851	1100.000	1112.129	1120.000	1140.000	1160.000	1180.000	1183.286	1190.702	1198.118	1200.000	1201.156	1220.000	1224.660										
区間距離	18.499	1.501	20.000	20.000	11.224	8.776	1.532	10.307	8.161	20.000	10.822	9.178	20.000	6.797	5.792	12.590	1.681	20.000	5.851	14.149	12.129	7.871	20.000	20.000	3.286	7.415	1.882	1.156	18.844	4.660												
測点	No. 43	No. 44	No. 45	No. 46	BC. 2	No. 47	SP. 2	EC. 2	No. 48	No. 49	No. 49	No. 50	No. 51	BC. 3	No. 52	SP. 3	EC. 3	No. 53	No. 54	No. 54	No. 55	No. 55	No. 56	No. 57	No. 58	No. 59	BC. 4	SP. 4	EC. 4	No. 60	IP. 4-1	No. 61	No. 61									
曲線	179° 57' 50"		IP. 2 IA=5-54-21 R=200.000 TL=10.317 CL=20.615 SL=0.266										180° 27' 07"					IP. 3 IA=7-12-47 R=200.000 TL=12.606 CL=25.178 SL=0.397					88° 29' 08"					273° 47' 08"					IP. 4 IA=5-40-00 R=150.000 TL=7.424 CL=14.835 SL=0.184					110° 59' 33"				

酒匂川流域下水道台帳

施設平面縦断図(図面番号 6)

幹線名 連絡幹線

1 : 500

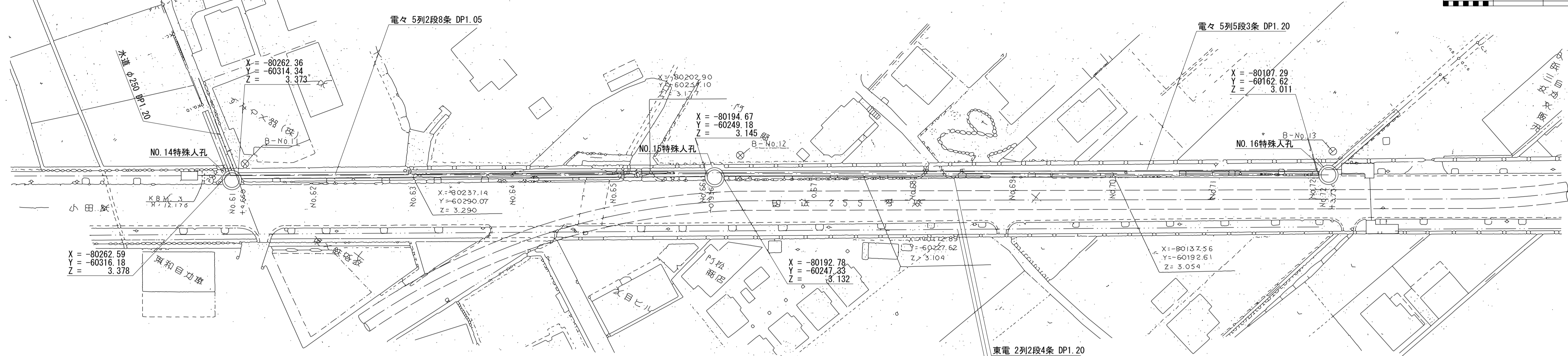

管渠構造図 S=1:50

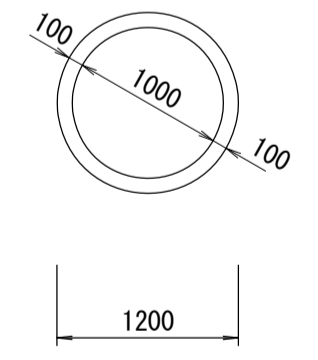
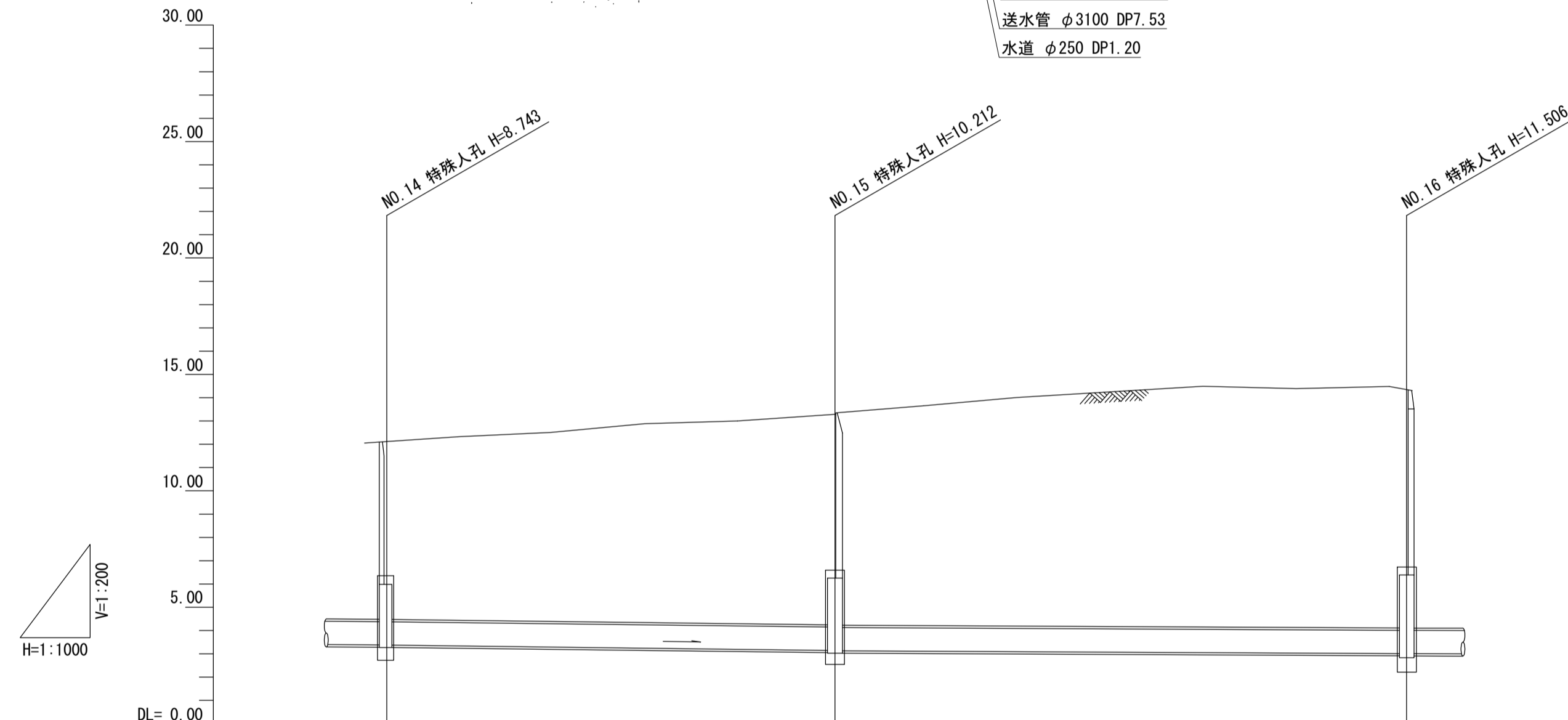

施工区	第104工区											
占用区間	国道255号線											
管渠築造												
土被り	7.606 7.643					9.040 9.112						10.226 10.406
地盤高	12.094 12.116	12.324	12.506	12.879	13.003	13.285 13.344	13.657	14.010	14.251	14.494	14.392	14.684 14.347 14.517
管底高	3.378 3.373					3.145 3.132						3.011 3.006
追加距離	4.660 1224.660	1240.000	1260.000	1280.000	1300.000	1320.936	1340.000	1360.000	1380.000	1400.000	1420.000	1440.000 1443.734
区間距離	4.660	15.340	20.000	20.000	20.000	20.936	19.064	20.000	20.000	20.000	20.000	3.734
測点	No. 61 +4.660	No. 62	No. 63	No. 64	No. 65	No. 66 +0.936	No. 67	No. 68	No. 69	No. 70	No. 71	No. 72 No. 73 +3.734
曲線	√ 110° 59' 33"			√ 180° 49' 34"				√ 138° 44' 01"				

酒匂川流域下水道台帳

施設平面縦断図(図面番号 7)

幹線名 連絡幹線

1 : 500

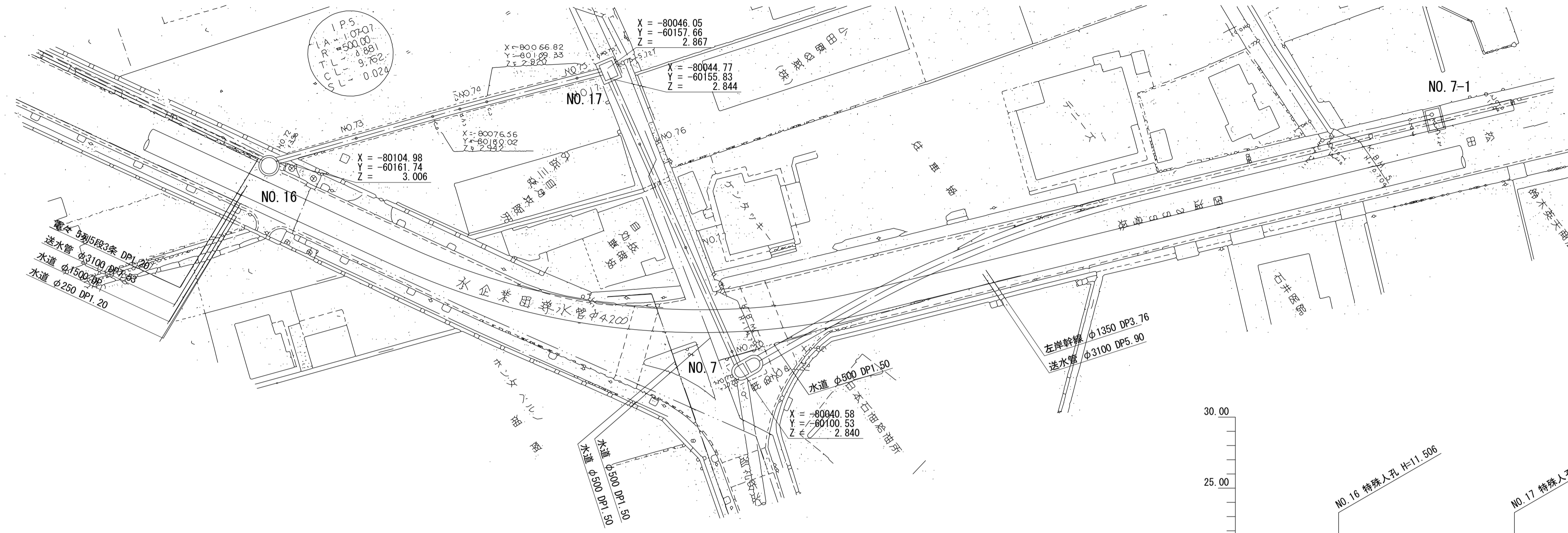

管渠構造図 S=1:50

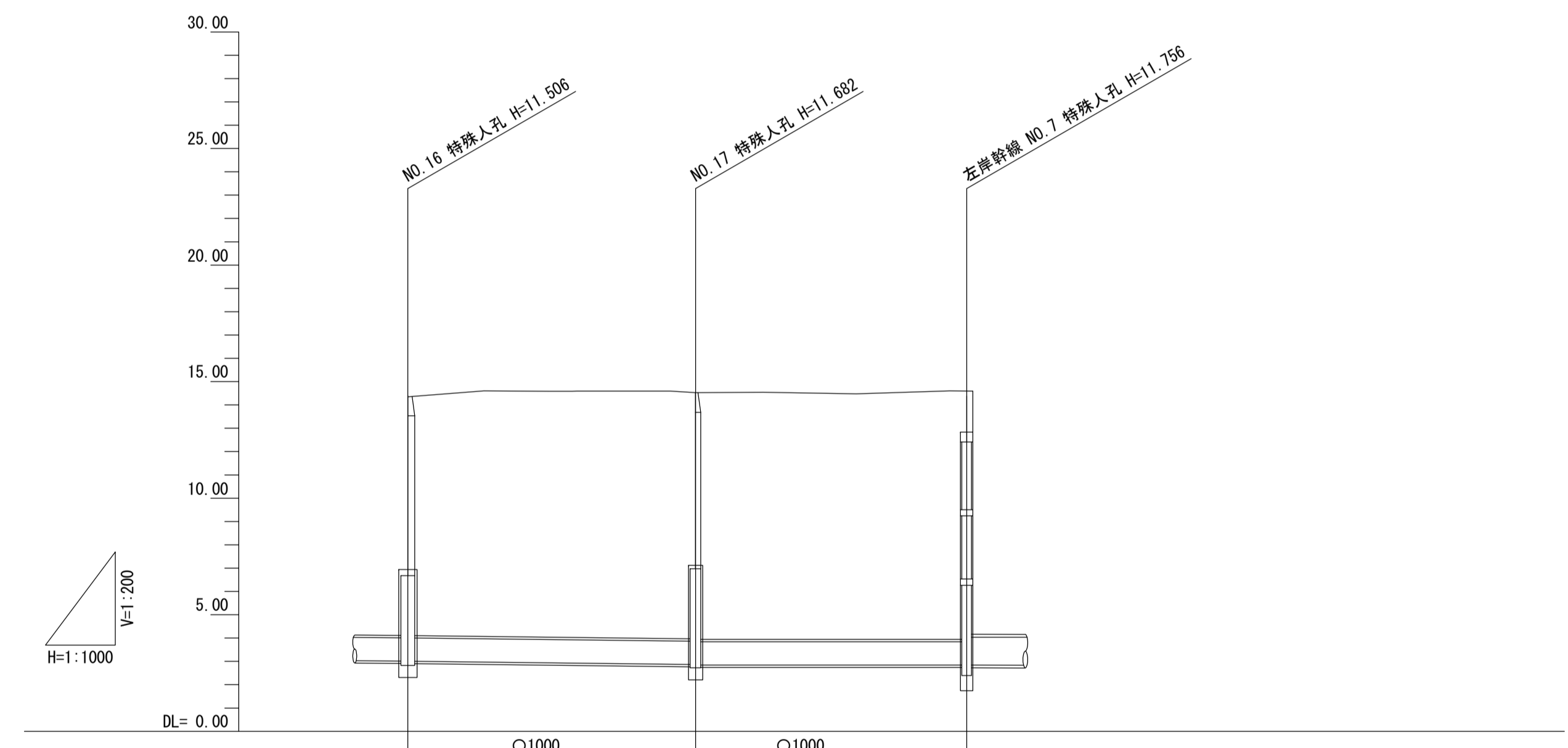
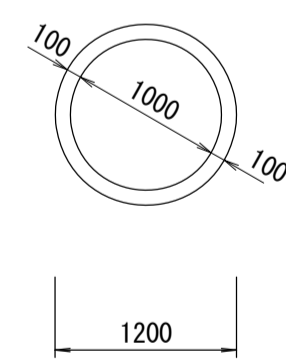

施工区	第105工区(推進工法)						
占用区間	小田原市(市道)			国道255号線			
管渠築造							
土被り	10.236	10.406		10.559	10.576		10.656
地盤高	14.347	14.512	14.606	14.587	14.587	14.520	14.543
管底高	3.011	3.006		2.867	2.844		2.840
追加距離	1443.734		1460.000	1474.088	1478.969	1483.000	1483.000
区間距離	3.734	16.266		14.088	4.881	3.680	16.150
測点	No.72 +3.734	No.73		BC.5 SP.5	BC.74 BC.5		No.75 No.76 +3.473
曲線	IP.5 1A=1-7-07 R=500.000 261° 4' 35"						
	TL=4.681 CL=9.762 SL=0.024						